

MONITOR YOUR DATA CENTER WITH PLUG-AND-PLAY SENSORS

Raritan's SmartSensors are a comprehensive set of sensors that monitor the environment within a data center. They are engineered to facilitate easy deployment while providing the most accurate data and insight into your operation. The advanced feature set allows for easy deployment, clear identification of hot spots, and better airflow management. SmartSensor models are available for monitoring temperature, humidity, airflow, air pressure, water/leaks, contact closures, proximity detection, vibration and more.

Environmental data collected by the sensors can be sent to DCIM monitoring software to provide a complete picture of data center conditions at the rack, aisle, and facility level. Real-time alerts of potential threats in your environment are also sent to administrators for fast resolution.

With Raritan's SmartSensors, adding environmental monitoring to your existing infrastructure is easier and more cost-effective than ever before. They set the new standard for easy data center deployment with its plug-and-play connection to any Raritan power device including PX Intelligent Rack PDUs, Smart Rack Controllers, PX Inline Meters, Rack Transfer Switches, and Branch Circuit Monitors.

PRE-INTEGRATED WITH RARITAN PX IPDUS, DCIM SOFTWARE

A seamless solution that works out-of-the-box with PX Intelligent PDUs, and Power IQ® DCIM monitoring software.



SMARTSENSOR BENEFITS

- Accurate monitoring of various conditions in your environment: temperature, humidity, airflow, air pressure, water leaks, and vibrations
- Easy deployment with scalable sensor technology
- Save on cooling by confidently raising data center temperatures
- Check airflow and air pressure to and from racks to prevent hot spots and bypass recirculation
- Improve data center uptime by receiving environment alerts to prevent hot spots, bypass airflow, and recirculation
- Make smarter rack management decisions based on factual environmental insights
- Easily install plug-and-play sensors without disrupting operations
- Improve field response-time to alerts with status LEDs
- Support for customizable configuration with bus/single technology

EASY COMPLIANCE WITH ENVIRONMENTAL STANDARDS

Environment sensors are one of the most useful tools needed to accurately report on all critical environmental conditions impacting your IT equipment and to make decisions to comply with ASHRAE standards.

Raritan's SmartSensors facilitate the collection of crucial environmental data and provide a more efficient deployment and management experience by pushing data into any DCIM or BMS software, through the Xerus™ Technology platform embedded in Raritan power solutions.

SENSORS FOR YOUR DATA CENTER



TEMPERATURE

The DX2-T1 can be placed at the front or rear of the rack to monitor cool air entering and/or hot air being expelled to ensure proper containment.¹



RACK INLET TEMPERATURE AND HUMIDITY

The DX2-T3H1 strings together 3 sensor heads, making it easy to mount them at the bottom, middle, and top of the cool air inlet side as per ASHRAE² guidelines.



AIRFLOW

The DX2-AF1 can meter airflow in plenum space (areas that are involved in the circulation of airflow), such as under a raised floor or just above the perforated tiles.



VIBRATION

The DX2-VBR detects vibrations such as earthquakes and damaged fans, along three axes (x, y, z).



WATER/LEAK

The DX2-WSF-KIT, DX2-WSC-35-KIT, and DX2-WSC-70-KIT sensors monitor leaks on the floor, around an area, on liquid cooled racks, and can detect condensation.



CONTACT CLOSURE

DX2-CC2 dual contact closure is used with third party sensors, and integrates with data center smoke detectors to monitor risky conditions and aggregate data through Raritan's Xerus Technology Platform.



DIFFERENTIAL AIR PRESSURE

The DX2-T1DP1 meters differential air pressure above and below a raised floor, or between hot aisles and cold aisles to prevent thermal leaks.

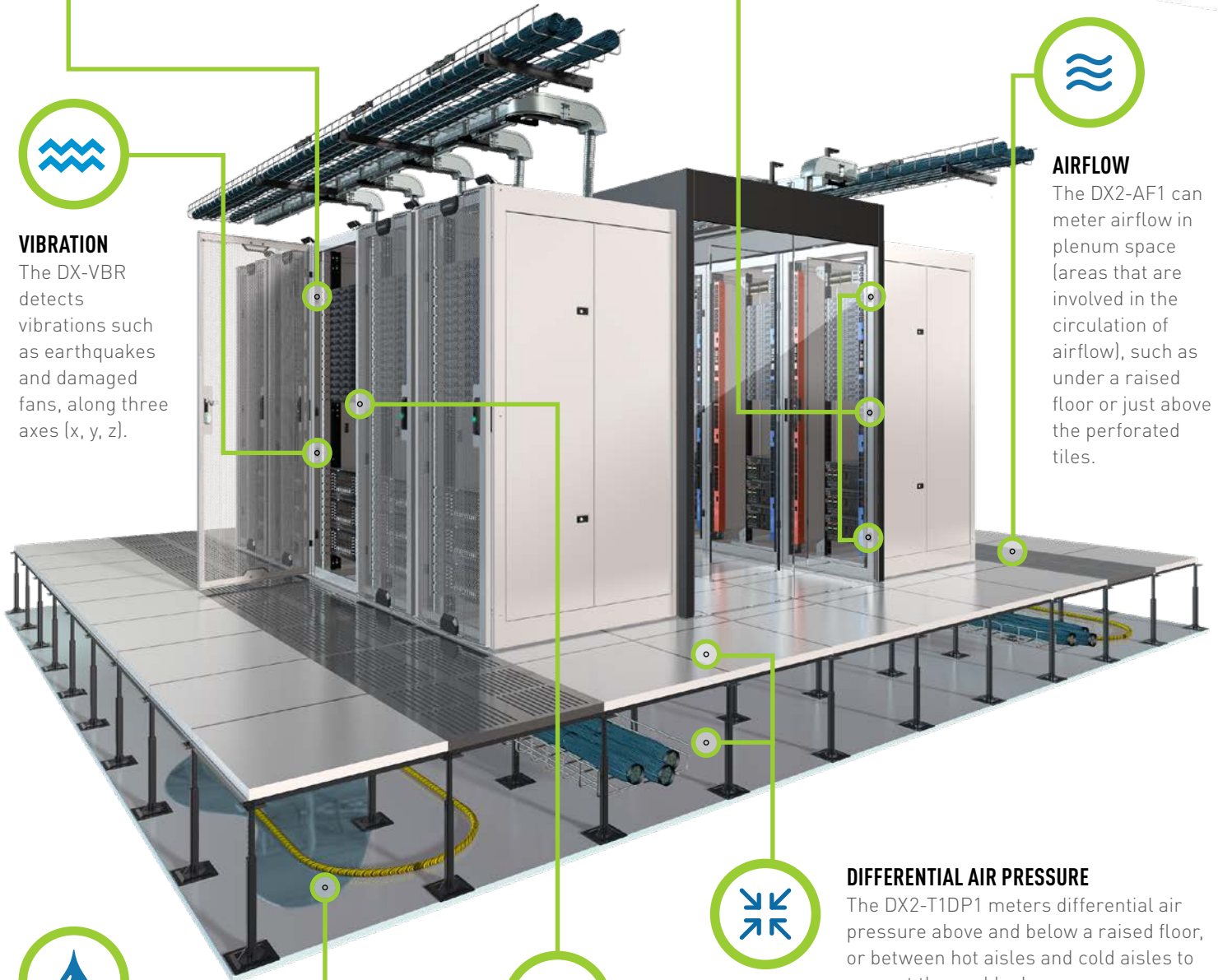

¹ Additional temperature and humidity sensor options are available.

² The American Society of Heating, Refrigerating and Air-Conditioning Engineers (ASHRAE) recommends measuring the cool air entering IT equipment near the bottom, in the middle, and near the top of each IT rack.

INNOVATIVE FEATURES

RJ45, REMOVABLE SENSOR HEADS

If sensor accuracy diminishes, you don't need to remove the entire sensor; just replace the sensor head to maintain a high degree of accuracy.



LED INDICATOR

LED light that visually alerts technicians when temperature thresholds are exceeded.

SINGLE BUS/STRING TECHNOLOGY

Offering the highest flexibility of deployment, SmartSensors can be cascaded in single bus structure to instrument entire rows of your data center with different types of sensors. Now cascade up to 32 sensor functions or up to 12 SmartSensor packages through a sensor port on a control device to ensure comprehensive measurement and monitoring. (Please note that a SmartSensor package may have multiple functions, such as the DX2-T3H1 Temperature/Humidity SmartSensor package which has 4 functions, 3 temperature functions and 1 humidity function.)

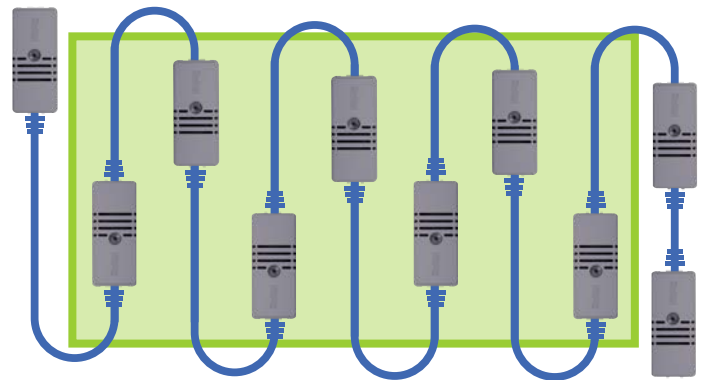

HIGH-ACCURACY AND HIGH-RELIABILITY METERING

All SmartSensors benefit from the latest, most high-tech metering components. SmartSensor delivers the highest metering accuracy at +/- 0.5°C for temperature sensors, +/-2.5% for relative humidity.

POWER IQ® DCIM MONITORING SOFTWARE

Environment data collected by SmartSensors can be sent to Power IQ® DCIM monitoring software, which allows you to confidently raise ambient temperatures and adjust the fan speed in CRAHs and CRACs to increase your energy savings and get the most out of your cooling systems.

Additionally, users can compare the data from sensors to the environmental envelope of a psychrometric chart to ensure that adequate cooling is where it needs to be, proper operating conditions have been maintained, and that they are in compliance with corporate, vendor, or utility guidelines.

Power IQ allows you to:

- See hot spots at-a-glance
- Know when to increase/decrease temperature set points
- Know how much to humidify
- Easily manage to ASHRAE standard thermal envelopes
- Simplify how you manage airside economization
- Customize and add your own thermal envelopes



Learn more at www.raritan.com/ap/poweriq

SMARTSENSOR™ MODELS

Type of Sensor	Part Number	Description	Range	Accuracy
SmartSensor: Temperature	DX2-T1	Single temperature sensor, field replaceable sensor module, RJ-45 connector	-20°C to 20°C 20°C to 70°C	+/- 2°C +/- 0.5°C
SmartSensor: Temperature and Humidity	DX2-T1H1	Single combo temperature and humidity sensor, field replaceable sensor modules, RJ-45 connector	-20°C to 20°C 20°C to 70°C 0% RH to 100% RH	+/- 2°C** +/- 0.5°C** +/- 5% /RH***
SmartSensor: Temperature and Humidity	DX2-T2H2	2x DX2-T1H1. Single combo temperature and humidity sensor, field replaceable sensor modules, RJ-45 connector	-20°C to 20°C 20°C to 70°C 0% RH to 100% RH	+/- 2°C** +/- 0.5°C** +/- 5% /RH***
SmartSensor: Temperature and Humidity	DX2-T3H1	1x DX2-T1h1 + 2x DX2-T1. Dual combo temperature and humidity sensors, field replaceable sensor modules, RJ-45 connector	-20°C to 20°C 20°C to 70°C 0% RH to 100% RH	+/- 2°C** +/- 0.5°C** +/- 5% /RH***
SmartSensor: Airflow Management	DX2-AF1*	Single airflow sensor, RJ-45 connector	N/R	N/R
SmartSensor: Differential Pressure	DX2-T1DP1*	Single combo differential air pressure and temperature sensor, RJ-45 connector	N/R	N/R
SmartSensor: Contact Closure	DX2-CC2	2 Contact Closure Sensor for connection and management 3rd party sensors (Smoke, sound, etc.)	N/R	N/R
Water/Leak Sensor	DX2-WSF-KIT*	Floor water/leak sensor, RJ-45 connector	N/R	N/R
Water/Leak Sensor	DX2-WSC-35-KIT*	11.5ft (3.5m) rope water/leak sensor, RJ-45 connector	N/R	N/R
Water/Leak Sensor	DX2-WSC-70-KIT*	23ft (7.0m) rope water/leak sensor, RJ-45 connector	N/R	N/R
Vibration Sensor	DX-VBR	Vibration sensor that detects acceleration along three axes (x, y, z). RJ-45 connector	0 to 13.86g	+/- 0.1g
<p>*DX2 Models T1DP1 and AF1 Will Be Available in 2020, Contact Your Raritan Representative for Availability. **when humidity is 20%–60% RH ***when temperature is at 25°C</p>				

Visit www.raritan.com/ap/SmartSensor

©2021 Raritan Inc. All rights reserved. Raritan® is a registered trademarks of Raritan Inc. or its wholly-owned subsidiaries. All others are registered trademarks or trademarks of their respective owners. Raritan began developing KVM switches for IT professionals to manage servers remotely in 1985. Today, as a brand of Legrand, we are a leading provider of intelligent rack PDUs. Our solutions increase the reliability and intelligence of data centers in 9 of the top 10 Fortune 500 technology companies. Learn more at Raritan.com V1191R11

Raritan
A brand of  **legrand**